



Using the analog to digital converter of the STM8S microcontroller

Introduction

The purpose of this application note is to explain how to use the Analog to Digital Converter implemented in many of the STM8S microcontroller family devices. It provides useful information on how to configure the ADC registers and microcontroller resources and use the ADC in different modes.

The STM8 firmware library, containing source code of all the examples described in this application note, can be downloaded from the STMicroelectronics website: www.st.com.

Contents

- 1 ADC hardware description 4**
 - 1.1 General properties 4
 - 1.2 ADC operation 6

- 2 Summary of features 8**
 - 2.1 Resolution 8
 - 2.2 Clock selection 8
 - 2.3 Conversion triggers 9
 - 2.4 ADC speed/sampling time 9
 - 2.5 Voltage reference 9
 - 2.6 Input analog channel selection 9
 - 2.7 Data storage 10
 - 2.8 Extended functions 10
 - 2.8.1 Buffers 10
 - 2.8.2 Buffer overrun flag 10
 - 2.8.3 Analog watchdog 11
 - 2.8.4 Scan mode 11
 - 2.8.5 Bandgap reference channel 11

- 3 Configuring ADC registers for conversion 12**
 - 3.1 Selecting the operating mode 12
 - 3.1.1 Single conversion mode 12
 - 3.1.2 Continuous conversion mode 12
 - 3.1.3 Conversion on external trigger 12
 - 3.1.4 Scan conversion mode 12
 - 3.2 Conversion speed selection 13
 - 3.3 Analog input selection 13
 - 3.4 Storing converted values 13
 - 3.5 Analog watchdog function 14
 - 3.6 ADC interrupt management 14

- 4 Practical application 15**
 - 4.1 Areas of use 15

4.2	Hardware connection examples	15
4.3	Methods for precision improvement	18
5	Design recommendations	19
6	Displaying the ADC conversion result using LEDs	20
6.1	Overview	20
6.2	Hardware description	20
6.3	Firmware description	20
7	ADC conversion triggered by TIM1 timer	21
7.1	Overview	21
7.2	Hardware description	21
7.3	Firmware description	21
8	Revision history	22

1 ADC hardware description

1.1 General properties

STM8 family microcontrollers include one Analog to Digital Converter which has up to 16 multiplexed inputs. Depending on the STM8 device, the ADC can be one of two types:

- A basic ADC type named ADC2
- An extended ADC type named ADC1

The resolution of both ADC types is 10 bits. The number of external analog inputs depends on the package size of the chosen STM8 family device.

The ADC is a successive approximation Analog to Digital Converter (SAR). Conversion can be performed in continuous mode or single mode. The analog input channels can be selected individually or in scan mode. In scan mode, several channels are converted in sequence, the channel number is incremented for each conversion. The digital result is then stored in registers. Because the ADC resolution is 10 bits and the ADC data register bit length is 16, one ADC result is stored in two 8-bit registers. The 10-bit data is either right or left aligned (this is selectable) in the 16-bit register. Devices with ADC1 can use buffered mode for data storage. In this case, the values converted by the ADC are stored in N data buffers (to decrease CPU overhead).

The event used to start conversion can be generated by software or by the STM8 microcontroller's internal timer 1 (any type of timer event can be used). The start of A/D conversion can also be triggered by an external pin.

The reference voltage for the ADC depends from package. It comes either from an external source - in this case the reference must be connected to two external pins - or is connected internally to analog power supply pins. The value of this reference voltage is restricted in its magnitude - must be from 2.75V up to V_{DDA} . The measured voltage must be between V_{REF+} and V_{REF-} . Resolution can be increased by so-called analog zooming - using a smaller reference voltage around the range of values to be measured.

Devices with ADC1 have an analog watchdog function. This function compares the converted data with high and low thresholds and if a threshold is reached then the analog watchdog flag is set.

If needed, an interrupt can be generated at the end of conversion and if an analog watchdog event occurred.

The ADC is driven by a clock derived from the MCU master clock through a programmable divider. This allows you to select the ADC clock speed according to your application requirements.

Figure 1. ADC2 block diagram (basic ADC)

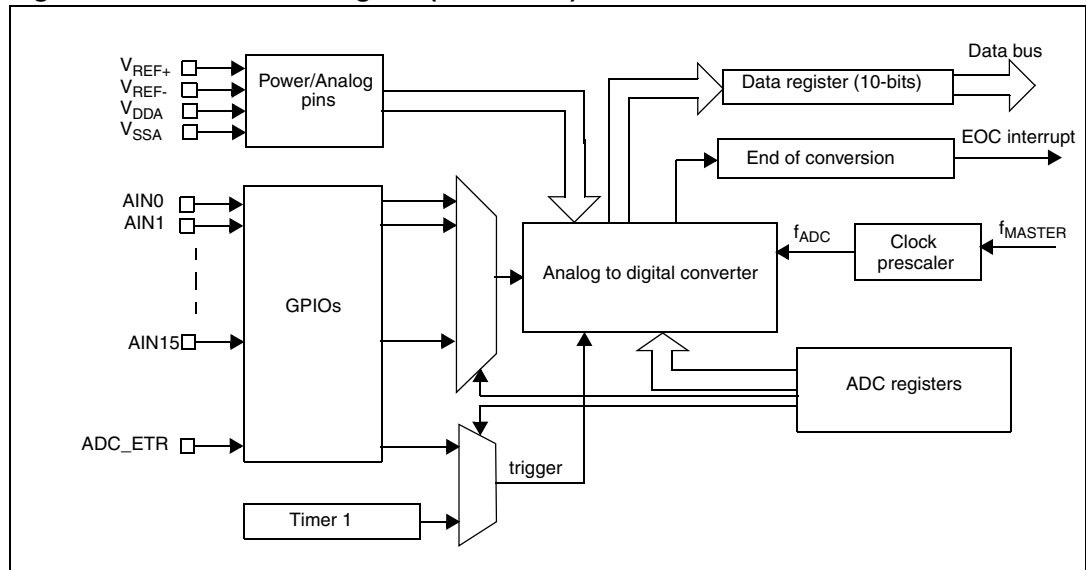
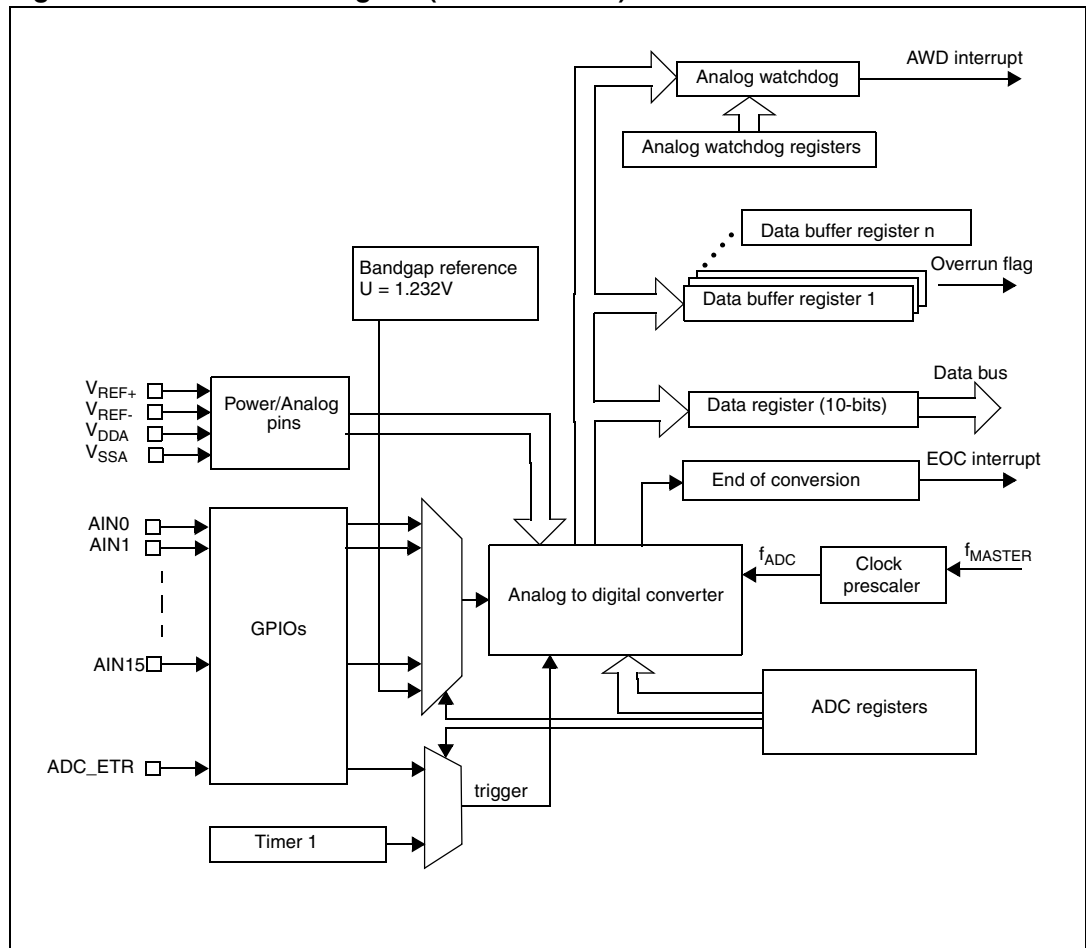

Figure 2. ADC1 block diagram (extended ADC)



1.2 ADC operation

The ADC can operate in single or continuous mode. In single mode, the ADC stops after one conversion. In continuous mode, it continues converting (on the same channel or different channel).

Figure 3. and Figure 4. describe ADC operation in single and continuous mode.

Figure 3. Single conversion mode

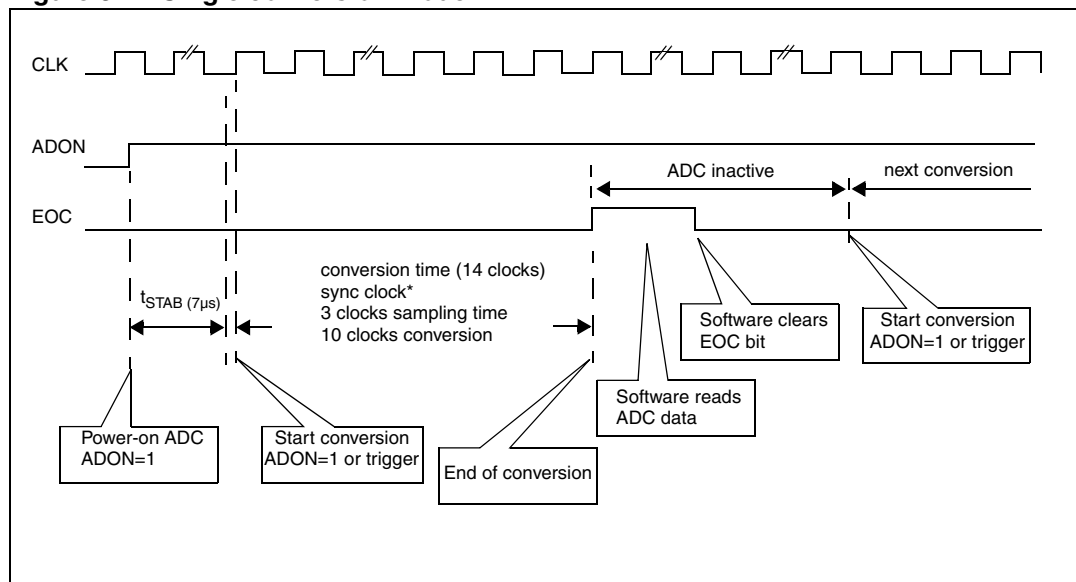
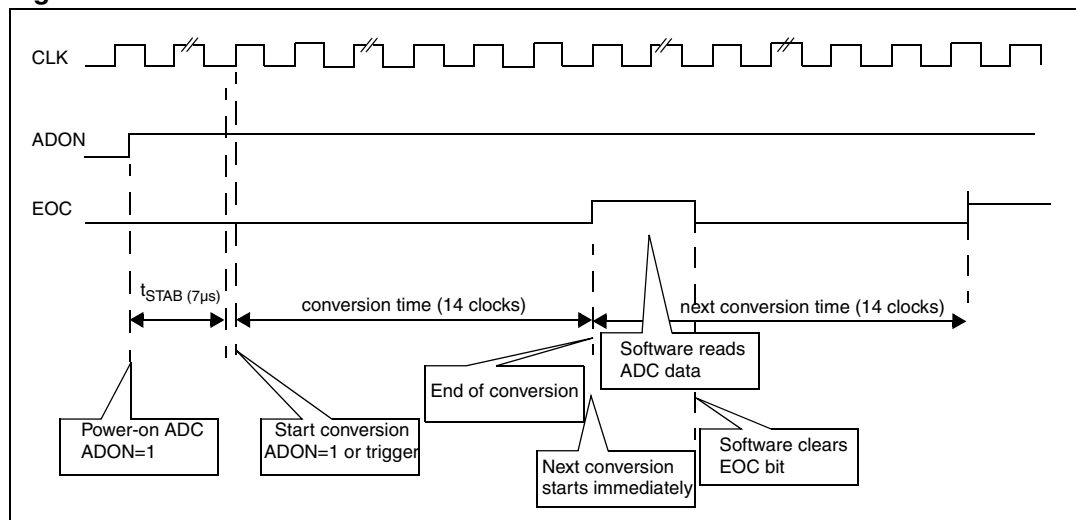

Figure 4. Continuous conversion mode



In devices with ADC1, these two modes can be usefully combined with scan mode and use of the data buffer registers (buffered mode).

Figure 5. shows all the possible ADC1 operating modes. ADC2 does not support scan and buffered modes.

Figure 5. ADC1 operating modes

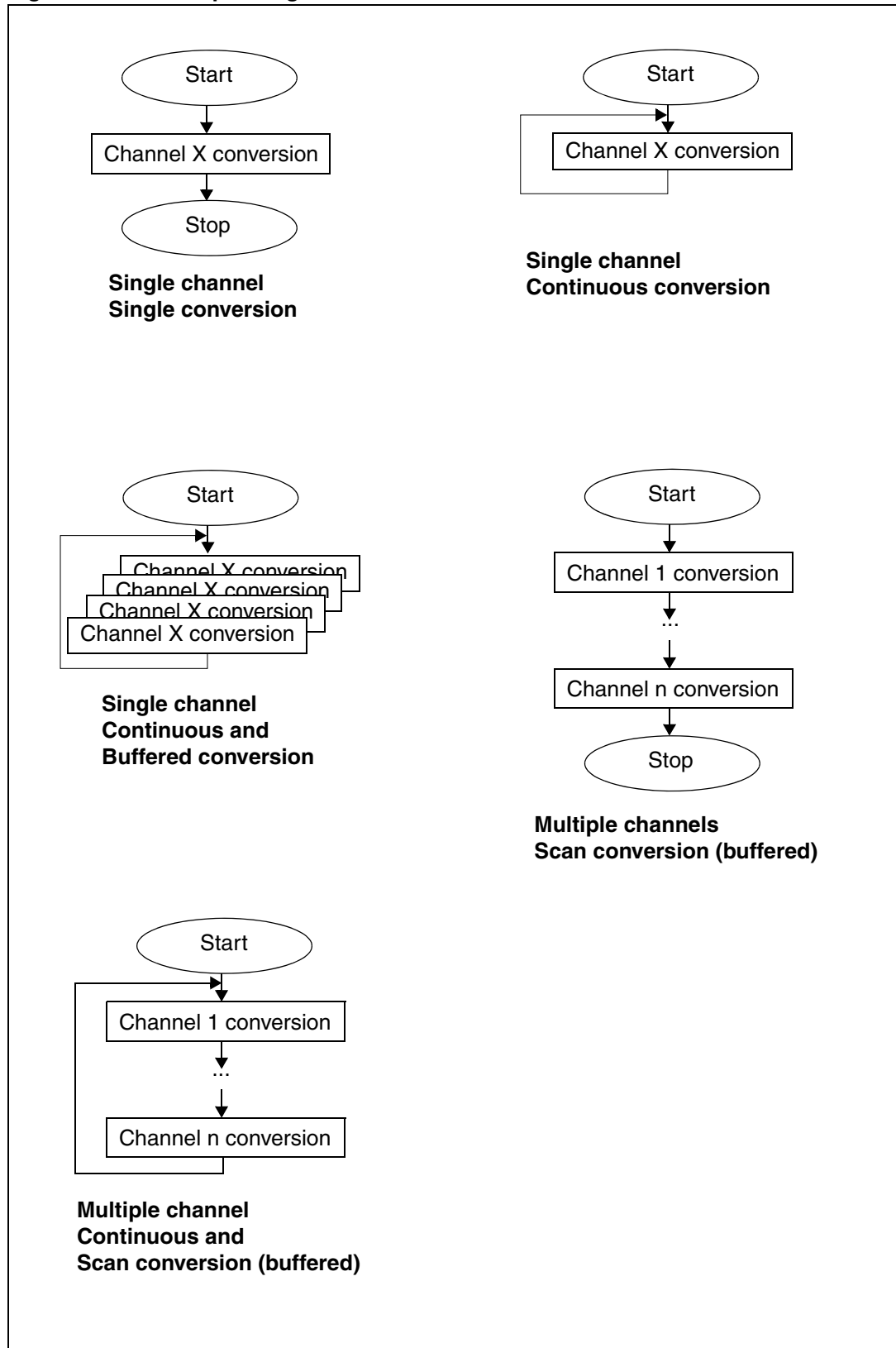

2 Summary of features

Table 1. below summarizes the main features of the STM8 ADC.

Table 1. STM8 ADC features

Feature	STM8 ADC
Resolution	10-bit
Clock speed	$f_{ADC} = 1$ to 4 or 6 MHz (refer to datasheet)
Triggers	Software, timer or external pin trigger
Operating modes	Single or continuous mode
Conversion speed	(14 clocks) 2.33 μ s @ 6 MHz f_{ADC}
Reference voltage	V_{REF+} and V_{REF-} external pins: 2.75 V \div V_{DDA} range, analog zooming possible Note: In some packages V_{REF+} and V_{REF-} are not available, in these cases the reference voltages are V_{DDA} or V_{DD} and V_{SSA} or V_{SS}
Number of input channels	Up to 16 channels
Data format	Optional left or right alignment
Buffers ⁽¹⁾	Up to 16 data buffer registers (depending on the number of channels)
Special functions ⁽¹⁾	Scan mode, analog watchdog, buffer overrun flag, bandgap reference voltage channel

1. Available only on ADC1 (extended ADC type)

2.1 Resolution

The STM8 ADC converter has 10-bit resolution. A special extra feature of the STM8 is that, to read the conversion results faster, and if you can accept lower resolution; you can read only 8 of the 10 bits, provided that you select the appropriate register alignment.

The register for configuring right or left data alignment is ADC_CR2.

2.2 Clock selection

The A/D conversion speed is given by the ADC clock signal. This clock speed must be between 1 MHz and 4 or 6 MHz (refer to datasheet). The ADC clock frequency is selected by dividing the frequency of the master clock.

The register for clock speed selection is ADC_CR1.

2.3 Conversion triggers

ADC conversion can be triggered by a Timer1 TRGO (trigger output) event or by a rising edge on the ADC_ETR external pin. Conversion can also be triggered by software, by setting the ADON bit.

The register for trigger selection is ADC_CR2.

2.4 ADC speed/sampling time

The ADC speed (and also sampling time) influences the measurement precision and must be chosen depending on the output impedance of the measured voltage source and the required conversion precision. The sampling time cannot be set independently from the ADC clock.

The ADC speed can be chosen from $f_{\text{MASTER}}/2$ down to $f_{\text{MASTER}}/18$ where f_{MASTER} is the microcontroller internal clock. The maximum speed of ADC conversion in the STM8 ADC is 2.33 μS .

The register for selecting the ADC clock division factor is ADC_CR1.

2.5 Voltage reference

The ADC reference voltage must be connected to the external pins or in most packages is connected internally to analog power supply. The reference voltage must be within the analog power supply range and the minimum reference voltage value is 2.75V.

2.6 Input analog channel selection

The STM8 ADC has up to 16 analog inputs connected to GPIO input pins. There are fewer analog inputs on some devices (this depends on the device package). Pins with ADC function must be configured as floating input and the input Schmidt trigger on these pins should be disabled (this reduces power consumption).

The register for selecting the input analog channel is ADC_CSR.

2.7 Data storage

The 10 bits of ADC converted data are stored in two 8-bit registers (and in ADC1 type also in the buffer registers - see [Figure 6.: Data alignment](#)).

The STM8 ADC has selectable data alignment. You can choose to left or right align the 10-bit ADC result in the two 8-bit data registers.

You must read the data registers in a particular order to ensure that the data retrieved from the registers is consistent (resulting from the same conversion). When the first data register is read, the second data register is latched so it can be read later and to prevent it being overwritten by the next conversion. The order in which you must read the data registers depends on the alignment mode. In right alignment mode, the LSB must be read first and then the MSB. In left alignment mode, the MSB must be read first and then the LSB.

Figure 6. Data alignment

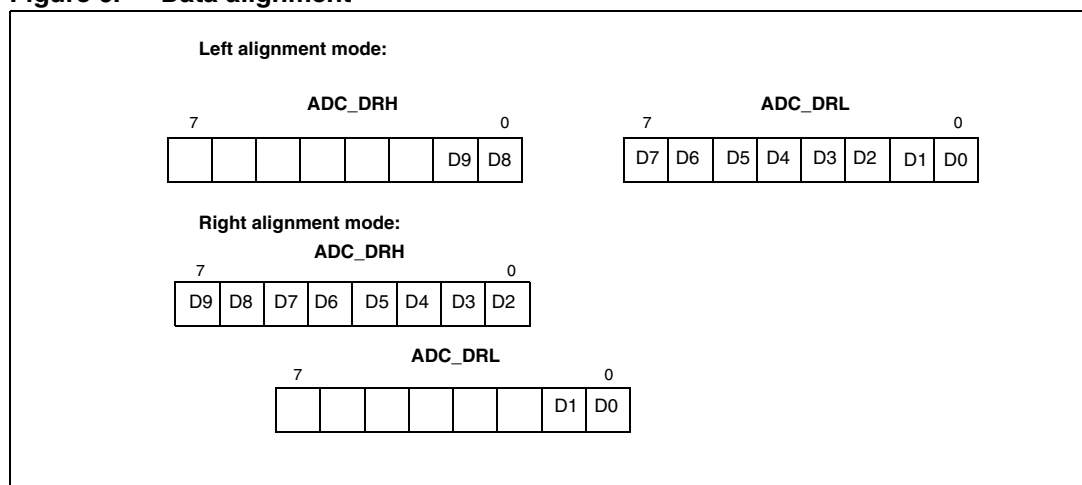

2.8 Extended functions

These extended functions are present only in devices with ADC1.

2.8.1 Buffers

Devices with ADC1 have a set of registers for data storage which are used when buffered mode is enabled. The converted data are stored cyclically in these registers (ring buffer). This makes data storage and collection more efficient (less CPU load and less data buffer overrun issues).

The number of data buffer registers is equal to the number of ADC1 input channels and depends on the STM8 device type.

2.8.2 Buffer overrun flag

This flag is set when the values in the ADC1 data buffer registers are overwritten before being read by the CPU. The user firmware can use this flag to detect an overrun event and can then perform appropriate actions (for example restart A/D conversion).

2.8.3 Analog watchdog

The analog watchdog compares the last converted value with high and low thresholds. When a threshold is reached then a flag is set and interrupt can be generated.

This is a useful way of checking for critical analog values without CPU intervention.

Figure 7. Analog watchdog operation

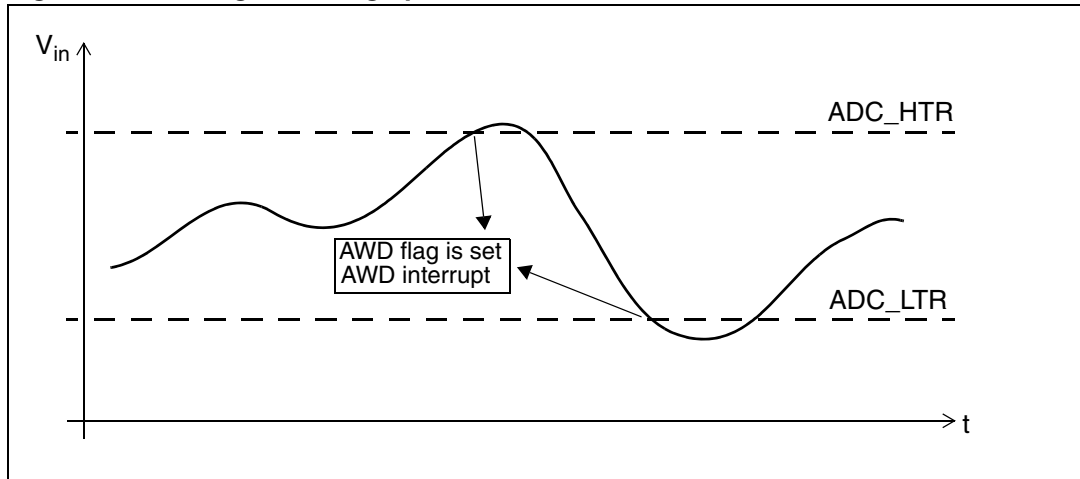

2.8.4 Scan mode

Scan mode allows AD conversion to be performed on consecutive channels. When one AD conversion is performed on the n-th channel, then channel n+1 is selected as input channel and the next AD conversion is performed on this channel.

The sequence of channels to be converted starts from channel 1 (always 1) to a selectable channel N. Channel N is set by programming the input channel selection bits.

If continuous mode is used together with scan mode, then the channels are cyclically repeated, from the N-th channel back to channel 1 etc.

2.8.5 Bandgap reference channel

Some devices with ADC1 have a bandgap voltage block which is connected to an input channel (usually the last channel). The purpose of this voltage block is to provide a stable, precise voltage reference for ADC calibration. Calibration may be needed because the analog supply (V_{DDA} and V_{SSA}), depends on an external power source.

The method of using the bandgap voltage for improving ADC accuracy is based on periodically performing an ADC conversion of the bandgap voltage input, then calculating an offset from the result and applying this offset to the results on the other channels. (postprocessing).

Refer to the device datasheet to determine if a bandgap reference channel is present in the STM8 device you are using.

3 Configuring ADC registers for conversion

3.1 Selecting the operating mode

The ADC converter can operate in different modes according to application requirements. The following sections list the various operating modes, the register settings required to use the ADC in each mode and the practical uses in each case.

3.1.1 Single conversion mode

In this mode, the ADC performs only one conversion. Conversion start is triggered either by software writing to the ADON bit or by a signal from Timer1 or from an external signal on the ADC_ETR pin (rising edge).

There must be a new start of conversion generated before the next single conversion (either by external trigger or by software).

Register settings:

ADC_CR1: CONT = 0

ADC_CR3: DBUF = 0 or 1 (data buffer registers not used or used)

Practical use: This mode can be used to collect an analog value from an external sensor (for example to read a temperature periodically).

3.1.2 Continuous conversion mode

In this mode, the ADC performs conversions cyclically. When one conversion has finished, then the next conversion starts immediately. Data must be collected from the data registers before they are overwritten by the next conversions.

Register settings:

ADC_CR1: CONT = 1

ADC_CR3: DBUF = 0 or 1 (data buffer registers "not used" or "used")

Practical use: To collect a set of analog values from an external analog signal (for example to read an AC voltage waveform).

3.1.3 Conversion on external trigger

Conversion can be started by writing to the ADON control bit or by external trigger. The external trigger source event can be a Timer1 TRGO event or a rising edge on the external ADC_ETR pin.

Register settings:

ADC_CR2: EXTSEL and EXTTRIG bits

ADC_CR3: DBUF = 0 or 1 (data buffer registers "not used" or "used")

Practical use: To measure analog values at regular intervals (timer trigger) or when a user input occurs (external pin trigger - pushbutton).

3.1.4 Scan conversion mode

In this mode, the ADC performs a sequence of conversions from channel 1 up to a selected channel number. When one conversion has finished, then the next conversion starts immediately on the next channel. Data are stored incrementally in data buffer registers

ADC_DBx (if DBUF bit is set) from which they must be retrieved before they are overwritten by the next set of conversions (especially if continuous mode is also selected).

Register settings:

ADC_CR2: SCAN bit

ADC_CR3: DBUF = 0 or 1 (data buffer registers “not used” or “used”)

Practical use: To collect a set of analog values from different inputs in one shot (for example to read a sample of several AC voltage waveforms almost simultaneously).

3.2 Conversion speed selection

The total conversion speed of an ADC depends proportionally on the ADC clock frequency, the sampling time duration and on the ADC resolution. The ADC clock speed must be selected by selecting the division factor to be applied to the internal master clock. The sampling time is not customizable and depends on the ADC clock (3 ADC clocks).

Register settings:

ADC_CR1: SPSEL[2:0] bits

3.3 Analog input selection

The device has up to 16 external analog inputs connected to GPIO input pins. Pins to be used as ADC input function must be configured as floating inputs and the input Schmitt triggers on these pins should be disabled to avoid unnecessary power consumption. If the application changes the analog input channel during conversion then the current conversion is stopped and the next conversion starts on the new channel.

If scan mode is selected then the channel bits define the top channel in the scan sequence (from channel 1 to the top channel).

Register settings:

ADC_CSR: CH[3:0] bits

3.4 Storing converted values

The converted ADC value is stored in the ADC_DRH and ADC_DRL registers. If buffered mode is selected then data are stored cyclically in the data buffer registers ADC_DBxRH and ADC_DBxRL (x= 0..N, N is device dependent, refer to the datasheet).

Because the converted value has a 10 bit length and the data registers have 2x8 bit length, it is possible to select left or right alignment of the conversion result in the data registers. In left alignment the 8 most significant bits are stored in a single register, in right alignment the 8 least significant bits are stored in a single register. This can be chosen to suit the application. Data register reading is buffered - when the first register is read, the second register is automatically stored in a shadow register to be read later. This prevents reading data register values from 2 different conversions.

The first register to be read depends on the data alignment. You must read the MSB first in left alignment mode and read LSB first in right alignment mode.

Right alignment has the advantage of fast read access when measuring low level signals. In cases where the result does not affect the high order bits, you can read only the least significant byte.

Practical usage: Left alignment is useful for fast read access to the conversion result in 8-bit resolution.

Register settings:

ADC_CR3: DBUF bit

ADC_CR2: ALIGN bit

ADC_CR3: OVR bit

3.5 Analog watchdog function

The converted ADC sample is compared with the high and low analog watchdog threshold registers. If the threshold is reached then the AWD flag is set and another status bit in the analog watchdog status register to indicate the channel on which the event occurred. The analog watchdog function can be enabled for selected channels only by setting the corresponding bits in the ADC_AWCRx control registers.

Register settings:

ADC_HTRH, ADC_HTRL, ADC_LTRH, ADC_LTRL - high and low thresholds

ADC_AWCRH, ADC_AWCRL - control registers

ADC_AWSRH, ADC_AWSRL - status registers

ADC_CSR: AWDIE and AWD bits

3.6 ADC interrupt management

ADC interrupt source(s) are selectable from one or more of the following events:

- End of conversion (EOC) in non buffered mode: generated after each AD conversion
- End of conversion (EOC) in buffered mode: generated after data buffer registers are full
- Analog watchdog alert: when converted values reach the high or low threshold values

Event-driven programming can be used for efficiency or for special software requirements. With this technique, when the main program is running, it is notified of state changes by events. You can enable the ADC interrupt to give the main program fast asynchronous event notification at the end of conversion(s). This means the main program does not need to poll the ADC conversion status flags but only has to process the ADC data results (for example after storing a set of conversions in a buffer). The reception of the ADC converted data values is performed by an interrupt routine in the background. In addition, the analog watchdog interrupt can be used for monitoring a given analog range on the measured channels.

Register settings:

ADC_CSR: AWDIE, EOCIE bits

4 Practical application

4.1 Areas of use

- Temperature measurement:
 - Process calibration
 - Device thermal protection
 - Fan control
- Power supply measurement:
 - Auto save configuration
 - Battery charging/protection
- Measurement of physical values in other types of application:
 - Automation: from sensors with analog outputs
 - Household: automatic lights dimmers, weather stations, thermometers, security sensors, ...
 - Industry: lights, thermostats, humidity control, ...
 - Electrical quantity measurements: voltage, current, capacity, resistance, ...

4.2 Hardware connection examples

Figure 8. Simple unipolar DC signal measurement

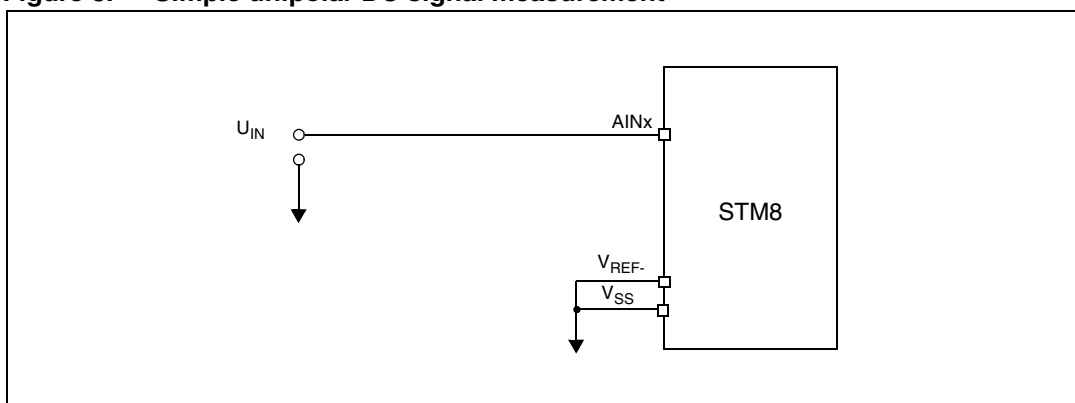

Figure 9. External preamplifier usage (with high impedance input)

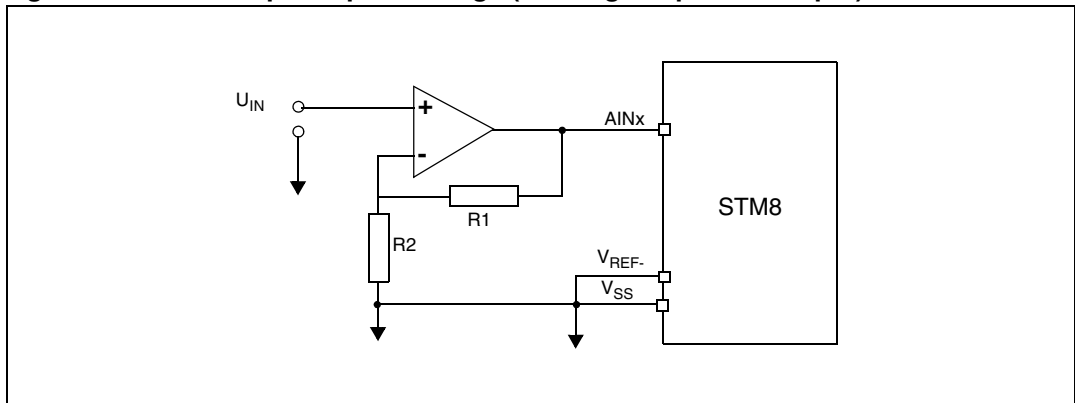

Figure 10. Differential DC signal measurement with preamplifier

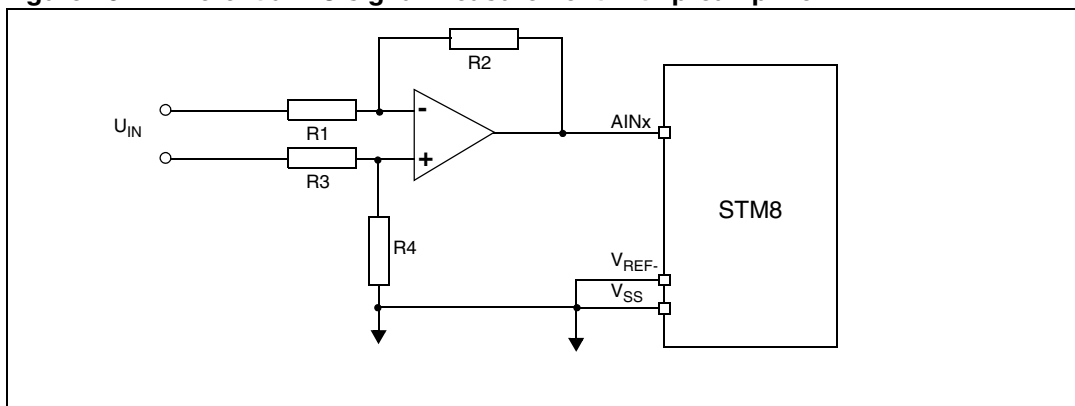

Figure 11. AC signal (FFT) measurement

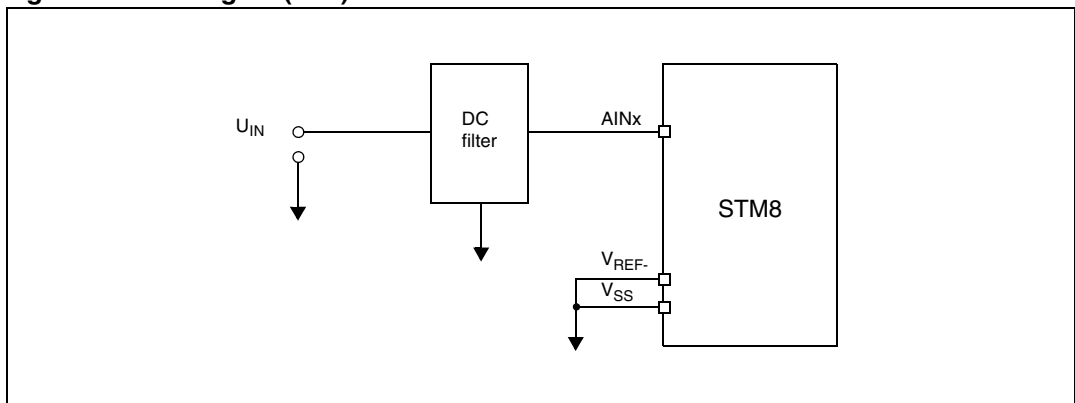

Figure 12. Analog zooming

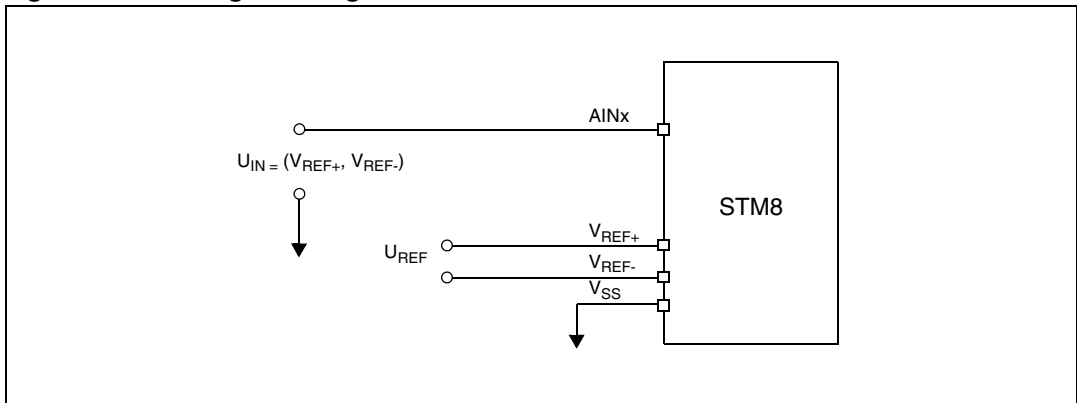
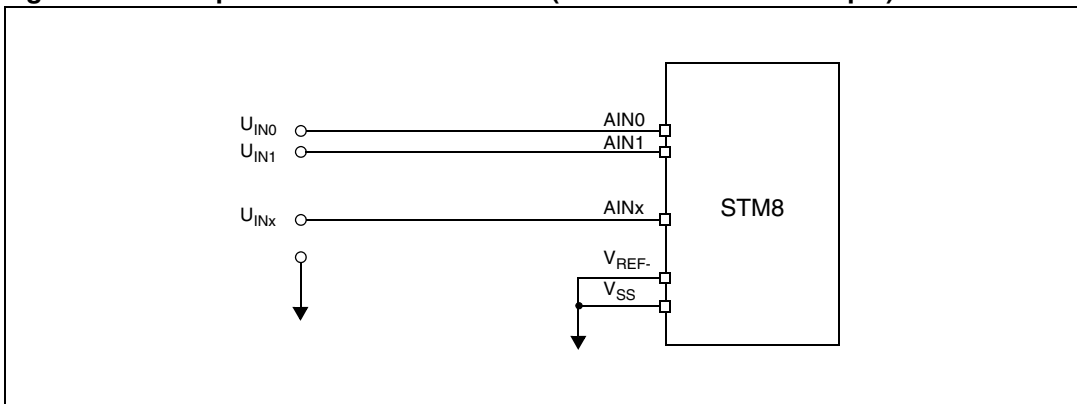

Figure 13. Multiple channel measurement (in scan mode for example)



4.3 Methods for precision improvement

- Averaging samples:
 - Averaging decreases speed but can give improved accuracy
- Analog zooming (use appropriate V_{REF} voltage and V_{REF} offset):
 - Select reference voltage between input signal ranges
 - Gives full ADC range - min. voltage per bit
- White noise added to measured signal: wobbling of input signal over several bits gives possibility to use averaging (if input signal is very stable)
 - White noise gives independence from sampling frequency
- Digital filtering (50/60 Hz suppression from DC value)
 - Set proper sampling frequency (The trigger from Timer1 is useful in this case)
- Perform software post processing on sampled data (comb filter)
- Fast Fourier Transform (FFT) for AC measurements:
 - To show harmonic parts in measured signal
 - Slower due to more computational power requirements
- Calibration of ADC: offset, gain, bit weight calibration
 - Decreases internal ADC errors
 - Internal ADC structure must be known
- Good hardware design:
 - Grounding
 - Reference voltage filtering
 - Power supply filtering
 - Preamplifier usage
 - Frequency independence
 - ...

Refer to AN2719 for more details.

5 Design recommendations

The following is a checklist of the main design rules for using the ADC.

- Grounding of analog/digital power:
 - Star topology
- V_{DDA} , V_{SSA} filtering:
 - RC, LC filtering
 - Avoid noise from noisy digital power
- V_{REF} selection - offset, value, precision:
 - Reference voltage source precision and stability to meet the required precision in the application and the ADC's capability
 - Reference voltage source value and precision according to the expected measurement range
- Source impedance vs. input impedance knowledge:
 - Use input buffers for measured signal
 - Impedance relation with required conversion speed
- External preamplifier usage:
 - For low (and also high) level signals
 - Amplifier speed and precision properties
 - Amplifier dependency from frequency
- Select appropriate ADC mode, speed, trigger
- Software methods: averaging, FFT, ...

6 Displaying the ADC conversion result using LEDs

6.1 Overview

This section describes how to use the ADC continuous conversion mode and display the result on LEDs.

The example shows how to use continuous conversion mode and observe the effect of changing the voltage values on the analog channel and observing the accuracy of the ADC conversion.

6.2 Hardware description

Figure 14 shows a typical connection between the STM8 AIN9 pin and a potentiometer.

Figure 14. Connection to a potentiometer

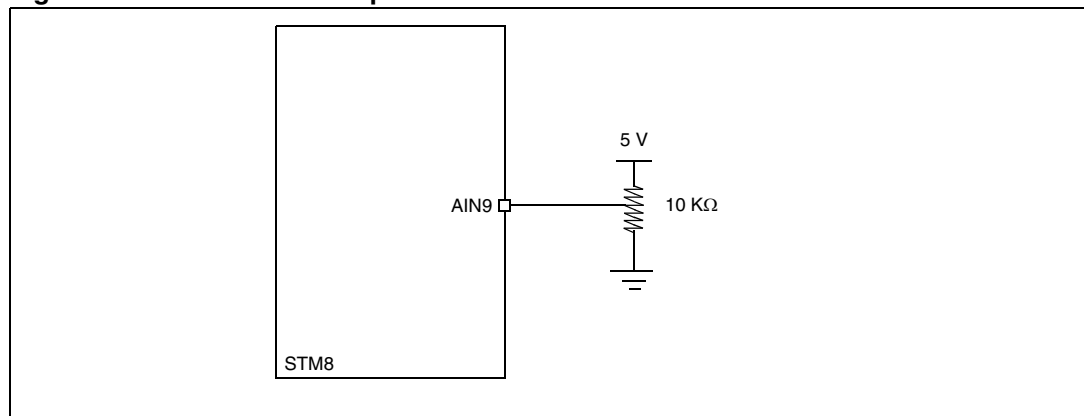

6.3 Firmware description

The STM8 firmware library includes the ADC driver that supports the ADC through a set of functions.

In this example the ADC is configured in continuous conversion mode with interrupt enabled. In the interrupt routine, the range of the converted value defines the number of LEDs to light up each time a conversion occurs. Increasing the voltage applied to channel 9 of the ADC, using the potentiometer, increases the number of LEDs that light up (up to 4).

This firmware is provided as *ADC example 1* in the STM8 firmware library, available from the STMicroelectronics microcontroller website.

7 ADC conversion triggered by TIM1 timer

7.1 Overview

This section describes how to start and ADC conversion triggered by the TIM1 trigger output.

There are several ways of starting ADC conversions in the STM8 including any event that can be generated by the multipurpose timer (TIM1). This gives the you a large choice when implementing your application.

7.2 Hardware description

Figure 14 shows a typical connection between the STM8 AIN9 pin and a potentiometer. This allows you to test the ADC by changing the input voltage to be converted. The conversion result is displayed on four LEDs. This example hardware is implemented in the STM8 evaluation board STM8/128-EVAL.

7.3 Firmware description

The STM8 firmware library includes the ADC driver that supports the ADC through a set of functions.

ADC is configured in continuous conversion mode with interrupt enabled. The conversion is triggered by the TIM1 TRGO event. In the interrupt routine, the range of the converted value defines the number of LEDs to light up each time a conversion occurs.

This firmware is provided as *ADC example 2* in the STM8 firmware library, available from the STMicroelectronics microcontroller website.

8 Revision history

Table 2. Document revision history

Date	Revision	Changes
28-Oct-2008	1	Initial release.
08-Jul-2009	2	Revised to describe ADC1 and ADC2 specific features.

Please Read Carefully:

Information in this document is provided solely in connection with ST products. STMicroelectronics NV and its subsidiaries ("ST") reserve the right to make changes, corrections, modifications or improvements, to this document, and the products and services described herein at any time, without notice.

All ST products are sold pursuant to ST's terms and conditions of sale.

Purchasers are solely responsible for the choice, selection and use of the ST products and services described herein, and ST assumes no liability whatsoever relating to the choice, selection or use of the ST products and services described herein.

No license, express or implied, by estoppel or otherwise, to any intellectual property rights is granted under this document. If any part of this document refers to any third party products or services it shall not be deemed a license grant by ST for the use of such third party products or services, or any intellectual property contained therein or considered as a warranty covering the use in any manner whatsoever of such third party products or services or any intellectual property contained therein.

UNLESS OTHERWISE SET FORTH IN ST'S TERMS AND CONDITIONS OF SALE ST DISCLAIMS ANY EXPRESS OR IMPLIED WARRANTY WITH RESPECT TO THE USE AND/OR SALE OF ST PRODUCTS INCLUDING WITHOUT LIMITATION IMPLIED WARRANTIES OF MERCHANTABILITY, FITNESS FOR A PARTICULAR PURPOSE (AND THEIR EQUIVALENTS UNDER THE LAWS OF ANY JURISDICTION), OR INFRINGEMENT OF ANY PATENT, COPYRIGHT OR OTHER INTELLECTUAL PROPERTY RIGHT.

UNLESS EXPRESSLY APPROVED IN WRITING BY AN AUTHORIZED ST REPRESENTATIVE, ST PRODUCTS ARE NOT RECOMMENDED, AUTHORIZED OR WARRANTED FOR USE IN MILITARY, AIR CRAFT, SPACE, LIFE SAVING, OR LIFE SUSTAINING APPLICATIONS, NOR IN PRODUCTS OR SYSTEMS WHERE FAILURE OR MALFUNCTION MAY RESULT IN PERSONAL INJURY, DEATH, OR SEVERE PROPERTY OR ENVIRONMENTAL DAMAGE. ST PRODUCTS WHICH ARE NOT SPECIFIED AS "AUTOMOTIVE GRADE" MAY ONLY BE USED IN AUTOMOTIVE APPLICATIONS AT USER'S OWN RISK.

Resale of ST products with provisions different from the statements and/or technical features set forth in this document shall immediately void any warranty granted by ST for the ST product or service described herein and shall not create or extend in any manner whatsoever, any liability of ST.

ST and the ST logo are trademarks or registered trademarks of ST in various countries.

Information in this document supersedes and replaces all information previously supplied.

The ST logo is a registered trademark of STMicroelectronics. All other names are the property of their respective owners.

© 2009 STMicroelectronics - All rights reserved

STMicroelectronics group of companies

Australia - Belgium - Brazil - Canada - China - Czech Republic - Finland - France - Germany - Hong Kong - India - Israel - Italy - Japan - Malaysia - Malta - Morocco - Philippines - Singapore - Spain - Sweden - Switzerland - United Kingdom - United States of America

www.st.com

